

SUPERCONDUCTING GRAVIMETERS BASED ON ADVANCED NANOMATERIALS AND QUANTUM NEURAL NETWORK

V. YATSENKO, S. KRUCHININ, P. BIDYUK

Abstract. The paper is focused on a new concept of a cryogenic-optical sensor intended for use in the space industry, geodynamics, and fundamental experiments. The basis of the sensor is a magnetic suspension with a levitating test body, a high-precision optical recorder of mechanical coordinates of the levitating body, and a signal-processing system. A Michelson-type interferometer with a laser diode and a single-mode optical fiber was used to measure the test body's displacements. The coordination of the laser diode coherence length and the difference in the interferometer optical lengths of the arms made it possible to eliminate coherent noise caused by interference from spurious reflections. The minimum recorded shift of the test body was 0.1 nm. The design of the sensor and the mathematical model of the superconducting suspension dynamics are presented. The results of experimental studies of a magnetic suspension together with an optical interferometric displacement sensor having a subnanometer sensitivity are shown.

Keywords: magnetic suspension, laser interferometer, optical fiber, displacement measurement, quantum neural network.

INTRODUCTION

Remote sensing today is one of the rapidly growing modern measurement technologies. This direction of studies and applications is an industry with the cost of billions of dollars, and the number of distant specific images of different parts of the Earth is continuously growing. Solutions of many practical problems depend on the widespread use of measuring systems and different principles they use. These problems include monitoring of natural resources based upon analysis of gravitational anomalies, study of global geodynamic processes, the Earth's gravitational field, motions of Earth's poles, etc. To increase accuracy of the observations, determining the location and orientation for long-term air flights and underwater vehicle navigations require knowledge of Earth's gravitational field, including its anomalies. Detailed information on the Earth's gravitational field is needed by many industries and applied sciences (space research, geology, navigation, science of the Earth's shape). An accurate fast detection of geodynamic processes can provide data on the origin and development of critical local and global environmental conditions. Another practical problem is in the need to obtain more accurate information on undiscovered minerals of the Earth.

A gravimeter is a very accurate tool [1, 2, 6] for measuring the gravity acceleration g . At present, accuracy of the best stationary ground-based gravimeters is $10^{-8} g$. For sea-based gravimeters, it is $10^{-7} g$, and the aviation uses its value of about $10^{-6} g$. Most gravimeters manufactured by industry are based on the properties of a stretched spring or elastic properties of springs made of quartz or some special alloys. Their accuracy is not sufficient to solve these problems. Since the accuracy of gravimeters based on traditional principles has become fundamentally exhausted, many developers over the past decades have tried to use unconventional approaches in attempts to create ultraprecise gravimeters [1, 2]. These attempts can be grouped by the method of non-contact suspension of the gravimeter sensitive mass, by the use of electric or magnetic forces, by the methods of measuring the gravimeter sensitive mass displacements (optical recording systems, Josephson effects as the basis of measurements, etc.), as well as by computer based methods of signal processing. A great advance in the improvement of gravimeters was made due to the financing of development of superconducting gravimeters. J. M. Goodkind described in detail a superconducting gravimeter [1]. As he stated, the basic design of a superconducting gravimeter has been unchanged for almost 30 years since his first publication [2]. The free-state (levitation) of a sensitive mass of this gravimeter is achieved due to the Brownback-Meissner effect [3, 4]. An alternative approach is based on the phenomenon of magnetic levitation. The research in this field began in the late 1960s as a natural consequence of development of a low-temperature applied superconductivity, the theory of electromechanical conversion of energy and methods of control theory, as well as the development of defense navigation systems in the xUSSR. The phenomenon of “magnetic potential pit” (MPP) [4–6], discovered in 1975, means that the magnetic attraction between two distant magnets can change to the magnetic repulsion only as a result of growing distance between them. In this case the attractive force between two distant magnets was considered as a force that increases as the distance decreases. In other words, MPP considers the minimum magnetic potential energy as a function of the distance, although, by the time MPP was discovered, the magnetic interaction was considered monotonic, i.e. without the possibility of having a minimum anywhere except for points on the boundary.

The objective of this study is to present the results on the development of a sensitive element and a method for assessing the gravitational perturbation that affects a levitating test body. The paper presents the concept of a cryogenic optical sensor, its design, a mathematical model of dynamics of a superconducting suspension, and its stability analysis. The results of experimental studies of a magnetic suspension and an optical interferometric displacement sensor with subnanometer sensitivity are presented.

CONCEPT OF A CRYOGENIC OPTICAL SENSOR

The sensor concept is based on three features and their combination [1, 2, 6, 7, 8]. First, this is a new type of superconducting suspension of a test body of highly sensitive gravimeter in a free state. Known superconducting suspensions [1–5]

use the concept of levitation based on the Brownback–Meissner effect [3], when the stable magnetic confinement without contact with other bodies arises due to the ideal diamagnetism of the superconductor, which ensures the expulsion of another magnet from its volume. As an example can be a superconducting magnet coil powered by the direct current. The test body of known gravimeters is, as a rule, continuous sphere. Instead of the superconductor diamagnetism, the new concept uses the zero resistance of a superconductor in the form of a thin closed loop, for example, a ring. Under certain conditions, due to the manifestation of the MPP phenomenon, such ring can steadily hang in a free state despite its diamagnetism that is practically not manifested and, according to well-known physical principles, makes the suspension inoperative. Another feature is the laser method for measuring the displacements of the test body, while known superconducting gravimeters use on the purpose sensors based on the Josephson effect (superconducting quantum interferometer sensors). The third feature is the use of modern signal processing methods to isolate very small disturbances against a background of significant noise levels that correspond to parameters of the measured gravitational field.

The choice of MPP as the basis for the levitation is explained by the two factors. The first of them is the desire to increase the sensitivity of the superconducting gravimeter, the second is to expand its dynamic range. The use of optical registration of the levitating sensitive mass displacements is also a new approach in the field of ultra-precise gravimeters. To process the signals of cryogenic optical gravimeter, it is proposed to use several processing steps. The first step is to compensate the noise affecting the base of the device. The second processing stage is focused on the use of the sensor inverse dynamic model [10]. The adaptive digital filtering is performed in the third stage of processing. In general, the novelty of the concept lies in the combination of a free sensitive mass suspension, an optical registration system, and new signal processing facilities. To our opinion, this approach to the sensor construction is implemented for the first time.

A superconducting gravimeter is a spring-type meter, in which, however, a magnetic returning force works as mechanical spring acting on a test superconducting body in an inhomogeneous magnetic field of superconducting rings or a permanent magnet. Due to the high stability of the superconducting currents, a highly stable non-dissipative spring is created. In equilibrium, the test body levitates in a position, where the gravitational force is balanced by a magnetic force acting in the opposite direction. When the gravity changes, the test body begins to shift from the zero position, and the electronic displacement sensor produces an error signal. By changing the current in the control ring, the auto-tuning system creates an additional magnetic field proportional to this signal, which keeps the test body in zero position. Since the returning force is proportional to the current, measuring the current in the control ring provides linear measurement of changes in the force of gravity.

In the model of sensitive element (Fig. 1), the test mass was in the form of a cylinder on which superconducting rings and a mirror for interferometric measurements were placed. Additional structural elements necessary for technological reasons were attached to this cylinder.

An effective use of the advantages of MSS (magnetic suspension system) which have almost unlimited sensitivity requires an appropriate system of regis-

tration of the test body displacement. To determine the test body positions in cryogenic element (CE), the use of a laser sensor was proposed. This made it possible to exclude probable disturbances in the position of test body caused by electric and magnetic fields as opposed to the conventional sensors used in previous systems. The modern interferometric methods and dynamic effects in the laser generation caused by weak external signals are used to detect ultra-small movements of the test body. The interferometric method can ensure the measuring accuracy of the test body coordinates not worse than 0.1 nm, what is sufficient to achieve the necessary sensor sensitivity. We have selected and implemented experimental schemes with laser displacement detectors, which provide measurements of the test body displacements and transformation of the signal into digital form for subsequent processing. It was shown that an optical sensor based on a diode laser with external resonator as a source of monochromatic radiation and a single-mode optical fiber as a channel for transporting light to a test body with maintaining the coherence of optical radiation that satisfies set requirements.

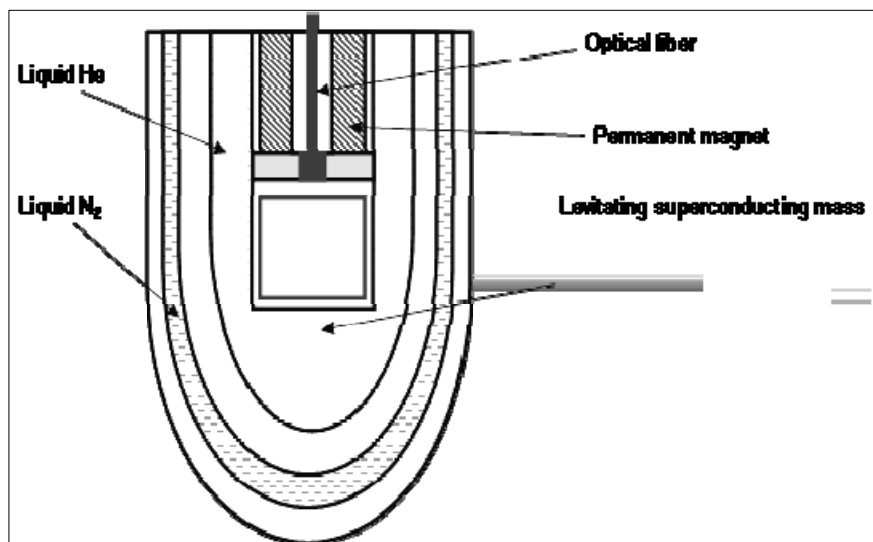

Fig. 1. The layout of the opto-cryogenic sensor

SENSOR DESIGN

The suspension is coaxial, i.e. the holding magnets are displaced from the coaxial position to the position, where their axes are parallel to the axis of the suspension (Fig. 2). From various options for the number of holding magnets (two, three, four), a system of four rare earth permanent magnets with a vertical axis was selected. Each magnet in the horizontal plane has a rectangular shape. The vertical positions of all four sets of magnets were shifted from the axis of the suspension so that a space of 18 mm in diameter was formed to accommodate the optical sensor. The problem of the non-vertical position of the suspended free sample, which arose as a result of the unequal magnetic properties of the sets of permanent magnets, was solved by two structural changes. One of them was an increase in the pendulous feature of the test mass and the other was reduced to a

thin ferromagnetic ring, which compensated for the azimuthal inhomogeneity of the suspension magnetic field.



Fig. 2. Design of the opto-cryogenic sensor

After theoretical and experimental studies of the suspension, optical sensor, and measurement software, the feasibility of the implementation of selected design as a whole was analyzed. As for the suspension, the main work concerned changes in the design of the magnetic system, when instead of placing remaining magnets on the axis of the suspension they had to be biased from the axis so that to place an optical laser sensor on it.

The new design of the working model (Fig. 3, 4) included four sets of permanent rare earth magnets, whose vertical axes of which were shifted from the suspension axis in four radial directions. The new design of the test mass had two niobium-titanium rings. The upper plane of the sample was polished as a reflective plane for laser beams. The levitation gap, depending on the weight of the test body, was from 7 to 15 mm. Based on this working model, theoretical and experimental studies of the joint operation of the suspension – registration system were carried out. The influence of the physical state of helium (liquid or gas) on the joint operation of the suspension – registration system was analyzed. The effect of a passive filter on the accuracy of the measurements was studied as well. The factors that influence a decrease in the suspension stiffness, in particular the presence of an additional ferromagnetic mass on a free sample were analyzed.

Experimental studies of the system were carried out to determine the properties of working model of a gravimeter, the dynamic characteristics of the magnetic suspension of free trial mass of the working layout of the gravimeter as well as the refinement of the sensitive element as a part of magnetic suspension, which was dictated by the experimental studies.

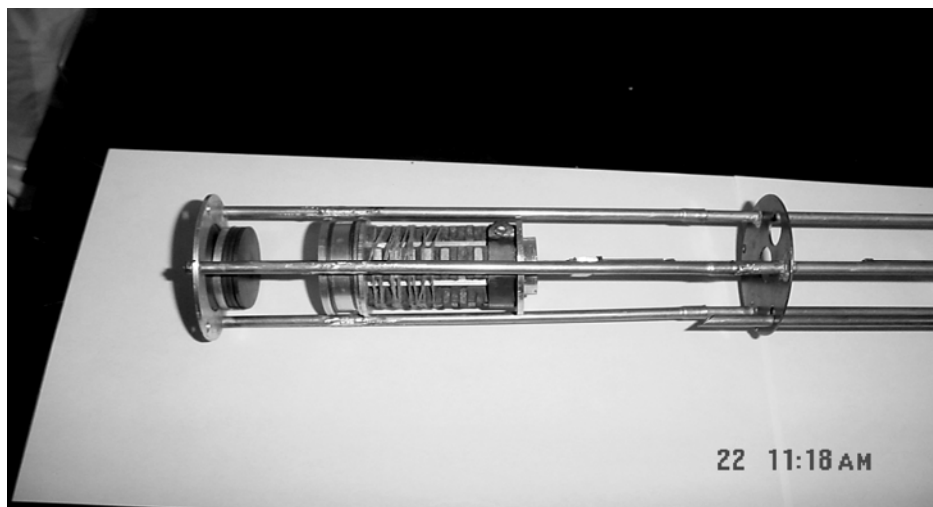

Fig. 3. Magnetic suspension system of four sets of holding permanent magnets

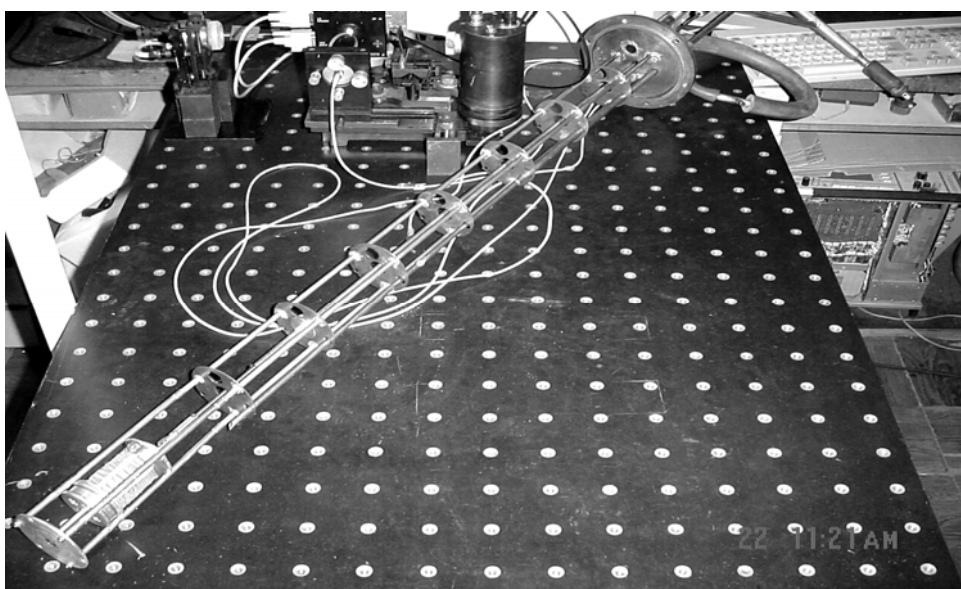

Fig. 4. Magnetic suspension system and optical system for the measurement of mechanical coordinates

SIGNAL PROCESSING SYSTEM

The signal processing system consists of an adaptive compensator, inverse dynamic sensor model, adaptive Kalman filter, and a digital filter. Instead of a reverse model, a special type of neural network can be used. The software integrates gravity perturbation estimation algorithms with data processing models. It also includes a subsystem for interaction of the program core with the database, as well as with algorithms for its interaction with the sensor. It is supposed to include the software modules implemented in Matlab. Special tools are provided to

significantly reduce the levels of internal and light-generating noises based on the use of the features of the detector operation and software.

The analysis of the noise intensity characteristics of the optical coordinate meter was conducted. The correlation function and spectral density of the noise were obtained with regard for the properties of the bandpass filtering in an interferometer and the arbitrary modulation of a wavefront. The analysis included the modulation of a fractional noise as a special case of noises. To detect a signal limited by a fractional noise, the signal-noise ratio was found as a function of the modulation parameters. And the procedure for optimizing the noise-signal ratio corresponding to the signal demodulation was developed.

A noise compensation algorithm based on the global optimization approach is proposed. The compensator can extract useful information from a noisy optical signal. The noise compensation system allows the use of two types of sensors. The primary sensor generates a noisy source signal, whereas the secondary sensor measures the noise that is not correlated with the useful signal, but is correlated with a noise in the primary sensor.

Neural network algorithms for the signal analysis and estimation of gravitational perturbations based on the information approach have been developed. The error of the entropy minimization approach in identifying the dynamics of a test body was studied. An influence of the Parseval clock window on the search for a minimum of the entropy was studied. It has been analytically proved that the minimum of the entropy can be local. At the same time, the global minimum of the entropy with nonparametric estimation can be found by using information from the Shannon and Gaussian kernels. A comparative analysis of minimizing the entropy of the error and minimizing the entropy of the least squared error of a short-term prediction of experimental data is carried out. The statistical properties of the error in estimating the high-order central moments of the experimental time series and forecasting are used as comparison criteria. A mathematical description of a new structure of the inhibitor-type neural network which belongs to an important class of neural networks is developed. The necessary conditions for the behavior stability of a competitive inhibitory neural network are determined, and an algorithm based on stability conditions is developed. An algorithm of implementation of an inhibitory neural network for the evaluation of a signal characterizing the position of a levitating body in space has been also proposed.

Testing of the software for estimation of gravity perturbations affecting the levitating test body was performed. A module for the asymptotic estimation of gravitational perturbations by optical measurements has been added to the software. The analysis of the signal evaluation quality of the levitating body disturbance using the sequential processing of “optimal filter – inverse model – adaptive filter” was made. To compare the evaluation qualities, the following criteria were used: the ratio of standard deviations of the estimated signals, least-square error of the estimate, and the correlation coefficient of the signal without noise and the estimated signal.

LASER DISPLACEMENT SENSOR OF A SUPERCONDUCTING GRAVIMETER

Recent advances in development of diode lasers and the fiber optic technology, progress in the development of laser interferometry methods offer an alternative

to commonly used electronic displacement sensors. The use of fiberoptic interferometers has several important potential advantages [1], providing: 1) the possibility of creating a linear highly sensitive displacement detector; 2) absolute displacement measurements with a natural scale such as the laser radiation wavelength; 3) a dynamic range sufficient to record the largest seismic disturbances; 4) minimal electrical noise; 5) minimum size, relatively easy production, and the lack of electromagnetic and thermal noises; 6) the ability to reduce drifts while using frequency-stabilized lasers.

Optical Measurement System Design

In the model of a superconducting gravimeter investigated in this paper, the motion of the test body was studied, by using an optical sensor — a laser fiberoptic interferometer. The laser interferometer is based on a 5-m long single-mode optical fiber, which made it possible to conveniently place the laser-optical unit relative to the cryogenic one. The test body had the shape of a cylinder on which a mirror was placed for interferometric measurements (Fig. 5).

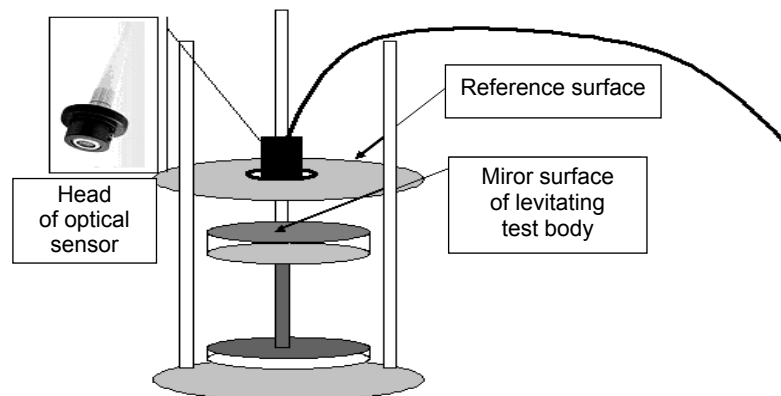

Fig. 5. The scheme of the insert in a cryostat with an optical gage head mounted on a supporting plane and with the levitating test body

The general scheme of the optical measuring system is shown in Fig. 6. It included:

- a source of laser radiation;
- fiber optic cable;
- photodetector;
- signal recording system;
- laser radiation monitoring system.

The laser diode radiation was fed into the optical fiber using a collimating lens. The reference beam of the interferometer was formed by reflecting part of the laser radiation that was fed into the fiber from the output end of the light guide, and the signal beam was formed by the reflection from the polished aluminum surface of the test body. In order to reduce the sensitivity of the device to the angular deviations of the test body, the output collimating optics was not installed, the amplitude of the signal beam rapidly decreased with increasing the distance from the output end of the fiber to the test body. A normal operating range was considered at distances in the interval 0.2 – 0.8 mm.

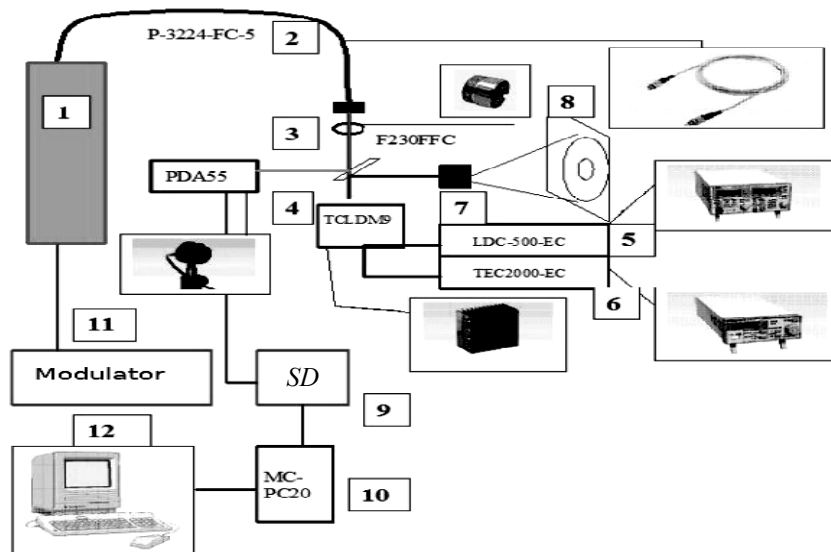

Fig. 6. Block diagram of the optical measuring system: 1 — cryostat with an insert on which an optical head is mounted; 2 — optical cable; 3 — focusing lens; 4 — a laser head with a laser diode; 5 — power supply of the laser diode; 6 — temperature stabilization unit; 7 — Fabry-Perot IFP-1 interferometer; 8 — screen; 9 — synchronous detector; 10 — analog-to-digital converter; 11 — modulator; 12 — computer

The reference and signal beams were returned through the fiber back to the laser optical unit, then reflected from the beam splitter and recorded by a photodetector.

The laser radiation source was based on a Hitachi semiconductor continuous laser HL6320G (emission wavelength 635 nm, output power 10 mW). The laser was placed in a TCLDM9 thermoelectric cooled laser head of Thorlabs Inc., which allowed the installation of diodes with a case diameter of 9 mm and 5.6 mm, allowing the modulation of a supply current in the frequency range from 100 kHz to 1 GHz and the precise control over the laser diode temperature. To feed the laser an LDC-500-EC electronic unit (Thorlabs Inc.) was used, which made it possible to set the laser diode current in the interval from zero to 500 mA with an accuracy of ± 0.2 mA. Noise in the frequency range of 10 Hz – 10 MHz does not exceed 5 μ A. The power supply had a mode for controlling the laser radiation power using the photodetector integrated in the laser diode case. The power supply current of the laser diode could be modulated using an external generator in the frequency range from DC to 150 kHz, the modulation coefficient is 50 mA / V.

The temperature of the laser diode was stabilized using a thermoelectric cooler built in a laser head, which was controlled by the TEC2000-EC thermal stabilization unit (Thorlabs Inc.). The temperature stability was 0.001 K, the adjustment accuracy was 0.01 $^{\circ}$ C.

The interferometer used a fiber optic cable P-3224-FC-5 (Thorlabs Inc.). The cable at both ends had ceramic caps, a numerical aperture of 0.12, a cut-off wavelength of 620 nm, is single-mode with a core diameter of 4 μ m, and a sheath diameter of 125 μ m. The cable length was 5 m. From the laser side, the radiation was fed into the optical fiber using an F230FFC-B collimating lens (Thorlabs

Inc.) with a diameter of 3.8 mm, a numerical aperture of 0.55, and a focal length of 4.5 mm. Optics were enlightened in the interval of 600–1050 nm.

As a photodetector, PDA55-EC silicon photodiode (Thorlabs Inc.) was used with a large receiving window area (13 mm²) with a low-noise amplifier, the gain of which was adjustable from $1.5 \cdot 10^4$ V/A to $1.5 \cdot 10^6$ V/A. With a minimum gain, the receiver bandwidth was at least 10 MHz.

The signal from the photodetector was either fed directly into an analog-digital 12-bit converter of MC-PC20 type or firstly into a synchronous detector to increase the signal-to-noise ratio, and then through an ADC to a personal computer.

To form the reference signal for the synchronous detector and to modulate the interference signal, we used a modulator, which generated an alternating high-voltage signal for supplying to the piezoelectric element to modulate the position of the reference plane of the interferometer. The recording system made it possible to record a continuous signal lasting 16s.

Properties of the fiber optic interference sensor and its maximum sensitivity

Interference signal. The light intensity detected by a photodetector depends on the distance x between the test body and the end of the fiber and can be represented as

$$I = I_0 R_0 \left\{ R_1 + (1 - R_1)TR + 2\sqrt{T(1 - R_1)RR_1} \Gamma(\chi) \cos\left(4\pi \frac{x}{\lambda}\right) \right\}, \quad (1.1)$$

where I is the light intensity at the photodetector, I_0 is the intensity of the laser radiation fed into the fiber, R_0 is the reflection coefficient of the dividing plate, R_1 is the reflection coefficient of the fiber end, R is the reflection coefficient of the surface of the test body, T is the collection efficiency of the fiber reflected from the surface of the test body, $\Gamma(\chi)$ is the correlation function of laser radiation, $\chi = \pi l / l_c$, where $l = 2x$ is the difference in the paths of the signal and reference rays, l_c is the coherence length of the laser radiation ($l_c = x\Delta\nu$, where c is the speed of light, and $\Delta\nu$ is the width of the laser radiation spectrum). In the case of white frequency noise, the laser emission spectrum has a Lorentzian shape, and the correlation function has the form $\Gamma(\chi) = \exp(-\chi)$.

The effect of laser radiation coherence. Thus, the interference is possible, if the path difference is less than the coherence length. The coherence length substantially depends on the type of laser. For example, for a gas single-mode laser, it is $l_c \approx 3$ km, while for laser diodes that were used in the described experiments, this value is less than 1cm. The relative smallness of the coherence length for laser diodes plays a very important role in the operation of a developed laser meter. In reality, in addition to the interference between the waves reflected from the test body and the end of the fiber, some of other interferences can be observed (e.g., the interference of waves reflected from the input and output ends of the fiber, etc.). This interference is an unwanted spurious effect that can significantly distort the useful signal. It is important that in the proposed scheme only a useful signal takes place, when the difference in the paths of the interfering waves is minimal, while, for all others, the difference in the courses contains the length of the fiber, which is 5 m in this experiment. Therefore, it can be expected that when using “bad” lasers with a short coherence length (but greater than the distance from the end of the fiber to the test body), the useful signal will not be distorted by the spu-

rious interference. At the same time, the use of “good” gas lasers will lead to a significant distortion of the signal.

To confirm this conclusion, an optical meter was experimentally tested for two cases where a He–Ne laser and a laser diode were used as a source. Fig. 7 illustrates the need to use low-coherence lasers. In this figure, the upper curve shows the interference signal, when using a gas laser, and the lower curve shows the interference signal for a laser diode.

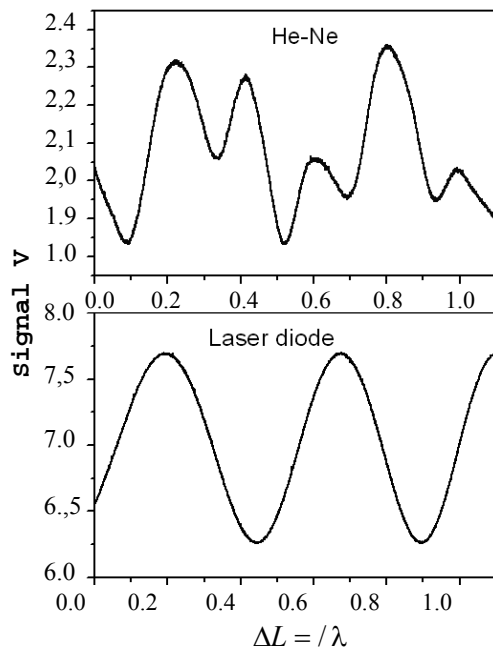

Fig. 7. Dependence of the photodetector signal on the displacement of the reflecting surface in the case of using a He–Ne laser (upper figure) and a laser diode (lower figure).

It can be seen that, in the first case, the interference pattern is distorted due to spurious reflections, whereas, in the other case, the ideal sinusoidal dependence of the signal is observed, when the position of the test body changes.

The sensitivity of the method.

For experimental determination of the minimum displacement of a test body which can be recorded by the developed optical sensor, the scheme shown in Fig. 8 was used. The mirror simulating the test body was mounted on a piezoelectric element to which a constant voltage was applied to control the movement of the mirror with sub-nanometer accuracy. The magnitude of a mirror displacement was determined by the magnitude of the applied voltage, based on the fact that the displacement of the mirror by a half

of the laser radiation wavelength ($\lambda / 2 \approx 0.32 \mu\text{m}$) would be at a voltage of 48V. The sensitivity of the interferometer was determined when tuning the region of the highest steepness of the dependence of the signal on the displacement of the mirror.

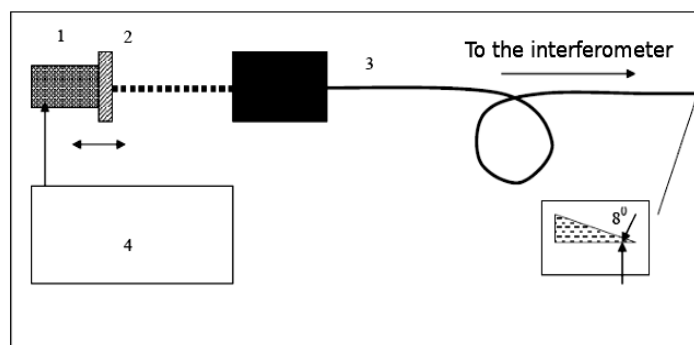

Fig. 8. Sensitivity calibration scheme of the optical sensor: 1 — piezoelectric element; 2 — mirror mounted on the piezoelectric element; 3 — optical sensor head; 4 — voltage source. The input end of the fiber is cut at an angle of 8°

Using a modulation technique to increase the sensitivity. The analysis of the noise of the optical measuring system showed that, with an increase in the frequency of observations, the spectral density of the noise rapidly decreases, reaching a constant value at frequencies above 5kHz, which is two orders of magnitude lower than the spectral density at low frequencies. Therefore, to increase the accuracy of the optical sensor, the modulation technique can be used, which makes it possible to transfer the registration frequency to the spectral region, where the system noise is minimal.

According to (1.1), the dependence of the interference signal on the position of the mirror x can be written as

$$S = a + b \sin 2kx,$$

where $k = 2\pi/\lambda$, a and b are constants. To eliminate the coordinate-independent component of the signal a , which makes the main contribution to low-frequency fluctuations, we modulate the distance to the test body with a frequency of Ω , $x = x_0 + \Delta x \cos(\Omega t)$.

The signal is recorded at the modulation frequency (or triple frequency) according to the formula

$$s_k = \int_0^{2\pi/\Omega} S(t) \cos(k\Omega t + \varphi) dt,$$

where $k = 1, 3$. After integration, we obtain, respectively:

$$s_1 = bJ_0(1, 2k\Delta x) \cos\varphi \cos(2k\Delta x)$$

and

$$s_3 = b \cos\varphi \cos 2k\Delta x \left(\frac{2J_1(2k\Delta x)}{(k\Delta x)^2} - J_1(2k\Delta x) - \frac{2J_0(2k\Delta x)}{k\Delta x} \right),$$

where $J_n(z)$ is the Bessel function.

Experimentally, the efficiency of the modulation technique was tested by changing the mirror position (or the position of the sensor optical head) with a frequency of 65Hz and with amplitude of about 0.1μm. The signal from the photodetector was fed to a selective amplifier, asynchronous detector, and an integrator and recorded by a computer. The registration of signals was performed

at a frequency of 65 Hz in a narrow frequency band (the averaging time was equal to 1 s), and the signal-to-noise ratio significantly increases. Fig. 7 shows the change in the signal with a stepwise displacement of the mirror with a step of 0.8nm. It can be seen that the use of the modulation technique even at a not very high modulation frequency leads to a significant reduction in the noise and, consequently, to a significant increase in the method

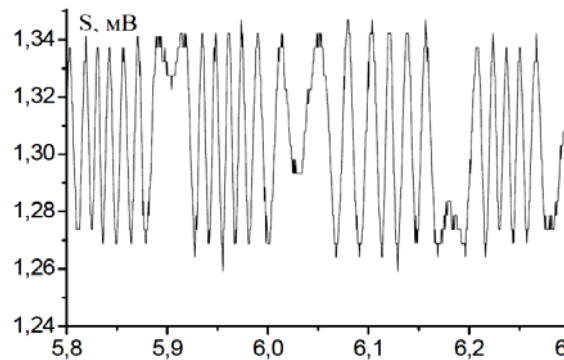

Fig. 9. Registration of oscillations of a test body with an amplitude of about 1.0 μm and an oscillation period of about 0.25 s

sensitivity. As follows from Fig. 9, the developed sensor allows to register displacements at the level of about 0.1 nm.

Model experiments

Given high cost of cryogenic experiments with relatively short levitation sessions in the gas phase, the development of the necessary technical solutions was carried out using models that recreate, as closely as possible, the real working conditions of a superconducting gravimeter. Based on the fact that the natural frequency of the developed test body was as low as several Hz, a scheme that recreates the dynamics of the test body by placing a reflecting mirror on a floating base was implemented.

It can be shown that the vertical oscillations of the body with an area of S that floats on the surface of a liquid with density ρ are described by the relation

$$m\ddot{x} = \rho g S x ,$$

where m is the mass of the float with a mirror, ρ is the density of a liquid, and g is the acceleration of gravity. The natural frequency of such a system is determined by the value $\omega = \sqrt{\rho g S / m}$ and can easily be changed by choosing the appropriate values of the system parameters. For model experiments, a system was used with $m = 0.05 \text{ kg}$, $\rho = 10^3 \text{ kg / m}^3$ (water), the float had the shape of a cylinder with a diameter of 50 mm. The oscillation frequency of such a system was about 3 Hz.

Fig. 10 shows the signal from an optical sensor, when the oscillation amplitude was about 1 nm. It can be seen that, during the period of oscillations, the mir-

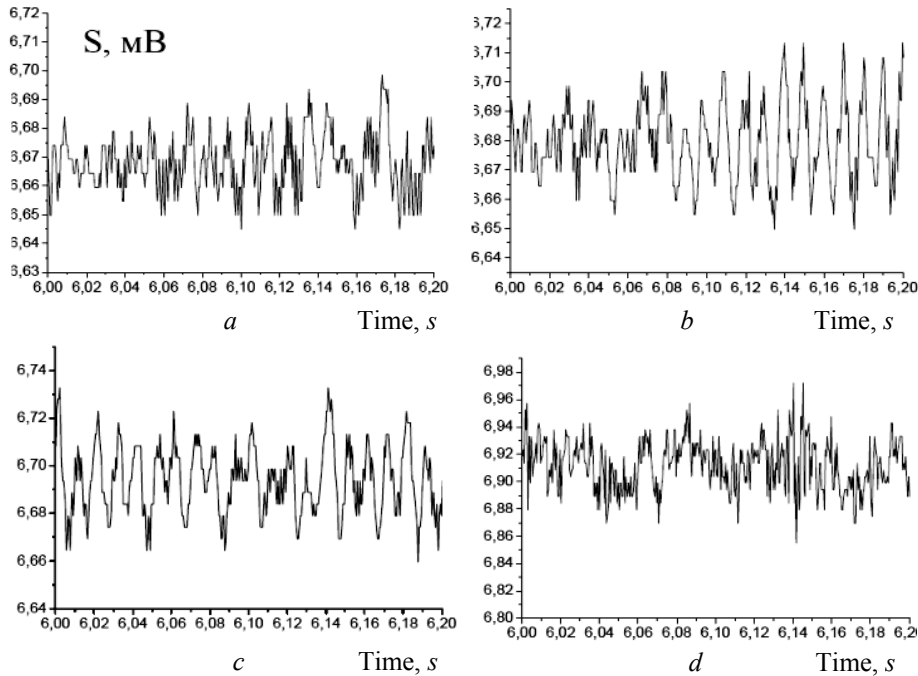

Fig. 10. An interference signal in the case of a levitating test body: *a–c* — fragments (0.2 s) of consecutive 16-second recordings of the interference signal, which were carried out after 3–5 min one by one. Levitating test body is in a gas environment without direct contact with liquid helium. *d* — the levitating test body is in direct contact with liquid helium

ror surface shifts by several half-waves, and the signal follows relation (1.1), in which the distance varies by the harmonic law.

The model experiments showed that the developed system makes it possible to register, after the appropriate mathematical processing of the obtained data, the vibrational motion of the test body with an amplitude greater than or comparable to the wavelength.

QUANTUM NEURAL NETWORKS

It is planned to use in gravimeter a quantum neural network based upon quantum automates. We studied the quantum computing within the constraints of using a polylogarithmic ($O(\log kn)$, $k \setminus 1$) number of qubits and a polylogarithmic number of computation steps. The current research in the literature has focused on using a polynomial number of qubits. A new mathematical model of computation called Quantum Neural Networks (QNNs) is defined, building on Deutsch's model of quantum computational network. The model introduces a nonlinear and irreversible gate, similar to the speculative operator defined by Abrams and Lloyd. The precise dynamics of this operator are defined and while giving examples in which nonlinear Schrödinger's equations are applied, we speculate on its possible implementation. Many practical problems associated with the current model of quantum computing are alleviated in the new model. It is shown that QNNs of logarithmic size and constant depth have the same computational power as threshold circuits, which are used for modeling neural networks. QNNs of polylogarithmic size and polylogarithmic depth can solve the problems in NC, the class of problems with theoretically fast parallel solutions. Thus, the new model may indeed provide an approach for building scalable parallel computers.

Our quantum neural network based on quantum automatons. This useful possibility was introduced by V. Yatsenko. He used controllable Schrödinger's equations and it was shown how converts it to a quantum automaton. We formulate a new paradigm for computing with cellular automata (CAS) composed of arrays of quantum devices-quantum cellular automata. Computing in such a paradigm is edge driven. Input, output, and power are delivered at the edge of the CA array only; no direct flow of information or energy to internal cells is required. Computing in this paradigm is also computing with the ground state. The architecture is so designed that the ground-state configuration of the array, subject to boundary conditions determined by the input, yields the computational result. We propose a specific realization of these ideas using two-electron cells composed of quantum dots. The charge density in the cell is very highly polarized (aligned) along one of the two cell axes, suggestive of a two-state CA. The polarization of one cell induces a polarization in a neighboring cell through the Coulomb interaction in a very non-linear fashion. Quantum cellular automata can perform useful computing. The authors showed that AND gates, OR gates, and inverters can be constructed and interconnected. This opens new way for implementation of the gravimeter proposed.

CONCLUSIONS

A gravimeter based on an optical sensor and a magnetic suspension of a superconducting test body was developed and experimentally investigated. The sensor

was studied at cryogenic temperatures, and procedures of data collection and processing were developed. Using the developed sensor, we studied the dynamics of a levitating test body in different environments (liquefied helium, cold helium vapor, etc.). On the studies of sensor's model its elements were refined to increase the sensitivity and to reduce the noise level.

An optical interferometric displacement sensor with subnanometer sensitivity was developed, created, and studied. The sensor was used to study the dynamics of oscillations of a test body with micron amplitudes, and it was shown that the proposed and experimentally implemented method for detecting the small displacements of the test body provides the possibility of using this method in superconducting gravimeters with adequate parameters of the sensitive element of a gravimeter. The achieved sensitivity of the optical sensor makes it possible to record a minimum displacement of the test body of the order of 100 pm, which with a natural frequency of oscillations of the test body of 0.2 Hz makes it possible to detect a change in the acceleration of gravity at a level of 10^{10} g. For estimation makes the acceleration of gravity at a level of 10^{-10} g we propose to use a quantum neural network based on quantum automatons.

REFERENCES

1. W.A. Prothero and J.M. Goodkind, "A superconducting gravimeter," *Rev. Sci. Instr.*, vol. 39, pp. 1257–1261, 1968.
2. J.M. Goodkind and R.J. Warburton, "Superconductivity applied to gravimetry," *IEEE Trans. on Magn.*, vol. 11, iss. 2, 1975.
3. J.M. Goodkind, "The superconducting gravimeter," *Rev. Sci. Instrum.*, vol. 70, no. 11, pp. 4131–4152, 1999.
4. F.C. Moon, *Superconducting Levitation: Application to bearings and magnetic transportation*. NY: John Willey & Sons, 1994, 295 p.
5. S. Kruchinin, *Modern Aspect of Superconductivity: Theory of Superconductivity*. World Scientific, 2010, 232 p.
6. V. Kozoriz, *Novel Magnetic Levitation and Propulsion Phenomena*. Zaporizhyya, 1999, 271 p.
7. V. Yatsenko and P. Pardalos, "Global optimization of cryogenic-optical sensor," in *Sensors, Systems, and Next-Generation Satellites, Proc. SPIE*, 4550, pp. 433–441, 2001.
8. V. Yatsenko, "Functional structure of cryogenic optical sensor and mathematical modeling of signal," *SPIE Conference 'Optical Science and Technologies', 3-8 August 2003, San Diego, CA, USA, Proc. of SPIE*, vol. 5172.

Received 03.08.2022

INFORMATION ON THE ARTICLE

Vitaly O. Yatsenko, ORCID: 0000-0002-7159-3312, National Technical University of Ukraine "Igor Sikorsky Kyiv Polytechnic Institute", Ukraine, e-mail: gsaudsai@gmail.com

Sergii P. Kruchinin, ORCID: 0000-0002-0674-5826, Bogolyubov Institute of Theoretical Physics, NASU, Ukraine, e-mail: skruchin@i.com.ua

Petro I. Bidiyuk, ORCID: 0000-0002-7421-3565, Educational and Research Institute for Applied System Analysis of the National Technical University of Ukraine “Igor Sikorsky Kyiv Polytechnic Institute”, Ukraine, e-mail: pbidyuke_00@ukr.net

НАДПРОВІДНІ ГРАВІМЕТРИ НА ОСНОВІ СУЧАСНИХ НАНОМАТЕРІАЛІВ І КВАНТОВИХ НЕЙРОННИХ МЕРЕЖ / В.О. Яценко, С.П. Кручинін, П.І. Бідюк

Анотація. Описано нову концепцію кріогенно-оптичного датчика, призначеного для використання у космічних дослідженнях, геодинаміці та фундаментальних експериментах. В основу датчика покладено магнітний підвіс з левітуючим тестовим тілом, високоточний оптичний реєстратор механічних координат левітуючого тіла і система оброблення сигналів. Як вимірювальну систему для визначення зміщень тестового тіла використано інтерферометр Міхельсона з лазерним діодом і оптоволоконном. Координація когерентної довжини лазерного діода і різниці оптичних довжин плечей інтерферометра дала змогу видалити когерентний шум, зумовлений інтерференцією від випадкових відбитків. Мінімально зареєстроване відхилення тестового тіла становило 0,1 нм. Подано процедуру проектування датчика, а також математичну модель динаміки надпровідної підвіски. Наведено результати експериментальних досліджень магнітної підвіски й оптичного інтерферометричного датчика відхилень, який має субнанометричну чутливість.

Ключові слова: магнітна підвіска, лазерний інтерферометр, оптичне волокно, вимірювання зміщення, квантова нейронна мережі.